

MAX2653 LNA with Gain-Step, Retuned for GPS applications

This application note presents alternate RF matching networks for the MAX2563 SiGe LNA, tuned for the GPS band (1575MHz center frequency). Performance metrics (supply current, forward gain, NF, IIP3, reverse isolation and input/output return loss) for both high and low gain modes, as well as 2.7V and 3.0V supplies are provided. For VCC=2.7V, high-gain mode, this application provides 19.2dB Gain, 1.6dB NF, and -5.2dB IIP3 at 5.6mA supply current.

The MAX2563 SiGe Low Noise Amplifier (LNA) is internally optimized for lowest noise performance in the US PCS (1930MHz to 1990MHz) and the European DCS (1805MHz to 1880MHz) receive bands. These LNAs offer a 20dB gain control step, externally adjustable gain and linearity (via single external resistor), 2.7V to 3.3V operation, and a 0.25 μ A shutdown mode. Maxim does not offer a stand-alone LNA for the GPS (1575MHz center) band that includes a gain-step, but re-tuning the MAX2563 to this lower band offers an excellent solution. These alternative matching values (Table 1) offer 0.5dB more gain, 0.1dB better noise figure, and 2dB better IIP3 - all for nearly identical supply current.

For applications that do not require a gain step, Maxim offers the MAX2654 and MAX2655 SiGe GPS LNAs. They offer a bias current control (via external resistor) to set gain and linearity, a 0.1 μ A shutdown mode and integrated 50 Ω output matching. Find the datasheet at <http://www.maxim-ic.com/max2654>.

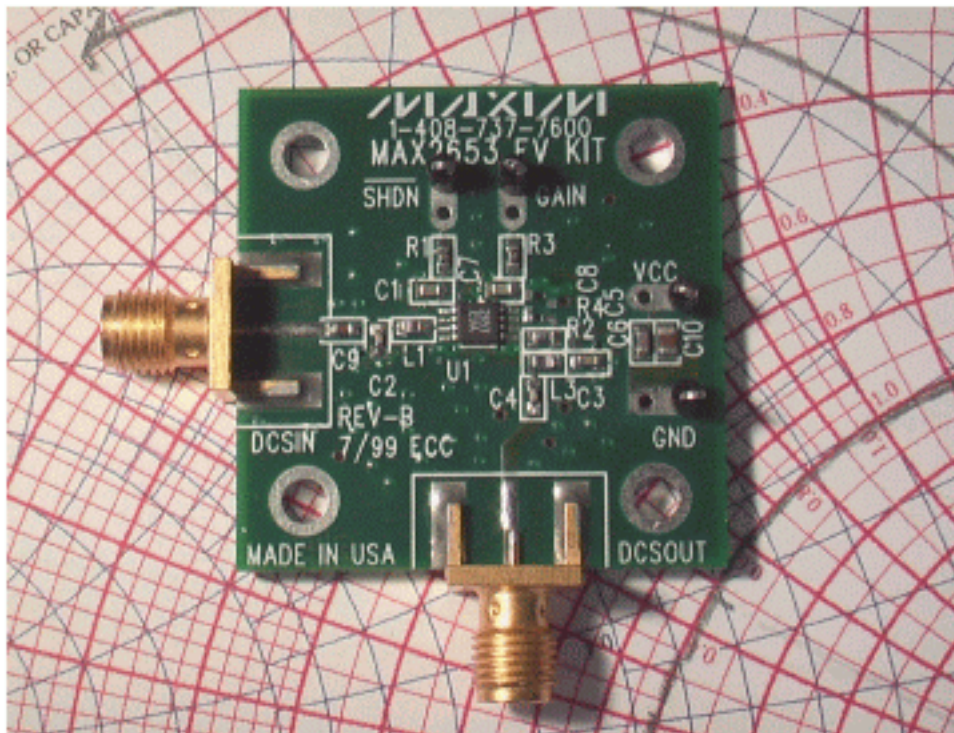

Figure 1. MAX2653 EVKit, with new matching components (C2, L1, L3, C4). No 'hacking' of the PCB necessary.

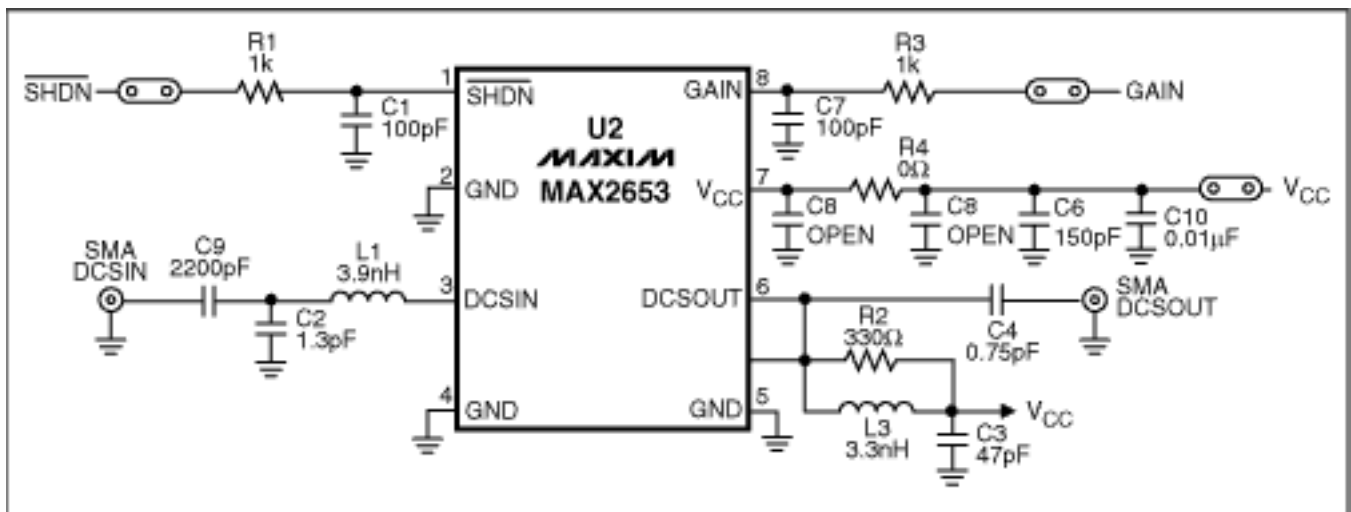

Figure 2. MAX2653 EVKit schematic, with new matching components for 1575MHz GPS band.

Table 1. MAX2653 EVKit replacement components for re-tuning to 1575MHz GPS band.

Designation	Value	Description
C2	1.3pF	shunt-C (to GND) matching component for LNA input 0402 ceramic capacitor Murata GJ61555C1H1R3CB01B
L1	3.9nH	series-L matching component for LNA input 0603 printed inductor Toko LL1608-FS series
L3	3.3nH	shunt-L (to V _{CC}) matching component for LNA output 0603 printed inductor Toko LL1608-FS series

C4	0.75pF	series-C matching component for LNA output0402 ceramic capacitor Murata GJ61555C1HR75CB01B
----	--------	---

After replacing the matching components on the EVKit, key performance metrics were re-tested at room temperature -- Table 2 provides the results of the re-tuned MAX2563 bench testing. These values are referred to the EVKit SMA connectors; to get values referred to the output of the matching networks, assume approximately 0.2dB loss at each the output and the input. In this fashion, the NF of the circuit is actually about 1.57dB, gain is about 19.2dB, and so on. Additional Gain and NF data over frequency is provided in Table 3.

Table 2. MAX2563 GPS performance summary. Results are referred to the EVKit SMA connector.

Parameter	Symbol	Conditions	Test Result	Unit	
Supply Current	ICC	High Gain Mode	V _{CC} =2.7V	5.61	mA
			V _{CC} =3.0V	5.62	
		Low Gain Mode	V _{CC} =2.7V	2.23	
			V _{CC} =3.0V	2.24	
Gain	G	High Gain Mode	V _{CC} =2.7V	19.0	dB
			V _{CC} =3.0V	19.0	
		Low Gain Mode	V _{CC} =2.7V	-2.3	
			V _{CC} =3.0V	-2.2	
NF	NF	High Gain Mode	V _{CC} =2.7V	1.77	dB
			V _{CC} =3.0V	1.79	
		Low Gain Mode	V _{CC} =2.7V	6.36	
			V _{CC} =3.0V	6.37	
Input 3rd-order Intercept	IIP3	High Gain Mode	V _{CC} =2.7V	-5.2	dBm
			V _{CC} =3.0V	-4.9	
		Low Gain Mode	V _{CC} =2.7V	+0.2	
			V _{CC} =3.0V	+0.2	
Reverse Isolation	S ₁₂	High Gain Mode	V _{CC} =2.7V	-33.8	dB
			V _{CC} =3.0V	-33.6	
		Low Gain Mode	V _{CC} =2.7V	-22.2	
			V _{CC} =3.0V	-22.3	

Input Return Loss	S11	High Gain Mode	V _{CC} =2.7V	-7.7	dB
			V _{CC} =3.0V	-7.7	
		Low Gain Mode	V _{CC} =2.7V	-10.9	
			V _{CC} =3.0V	-11.0	
Output Return Loss	S22	High Gain Mode	V _{CC} =2.7V	-12.6	dB
			V _{CC} =3.0V	-12.5	
		Low Gain Mode	V _{CC} =2.7V	-8.1	
			V _{CC} =3.0V	-8.2	

Table 3. MAX2563 GPS gain and NF performance over frequency. Results are referred to the EVKit SMA connector.

Frequency	High-Gain				Low-Gain			
	V _{CC} =2.7V		V _{CC} =3.0V		V _{CC} =2.7V		V _{CC} =3.0V	
	Gain (dB)	NF (dB)	Gain (dB)	NF (dB)	Gain (dB)	NF (dB)	Gain (dB)	NF (dB)
1400	15.4	1.71	15.3	1.69	-5.4	6.36	-5.5	6.32
1450	18.4	1.74	18.4	1.74	-2.9	7.18	-2.9	7.40
1500	18.6	1.75	18.5	1.77	-2.6	6.45	-2.6	6.59
1550	18.6	1.78	18.6	1.75	-2.9	5.70	-2.7	5.51
1575	19.0	1.77	19.0	1.79	-2.3	6.36	-2.2	6.37
1650	18.7	1.86	18.7	1.82	-2.2	6.67	-2.3	6.66
1700	17.3	1.84	17.4	1.87	-3.5	5.64	-3.5	5.56
1750	16.3	1.88	16.3	1.92	-4.3	6.26	-4.1	6.21

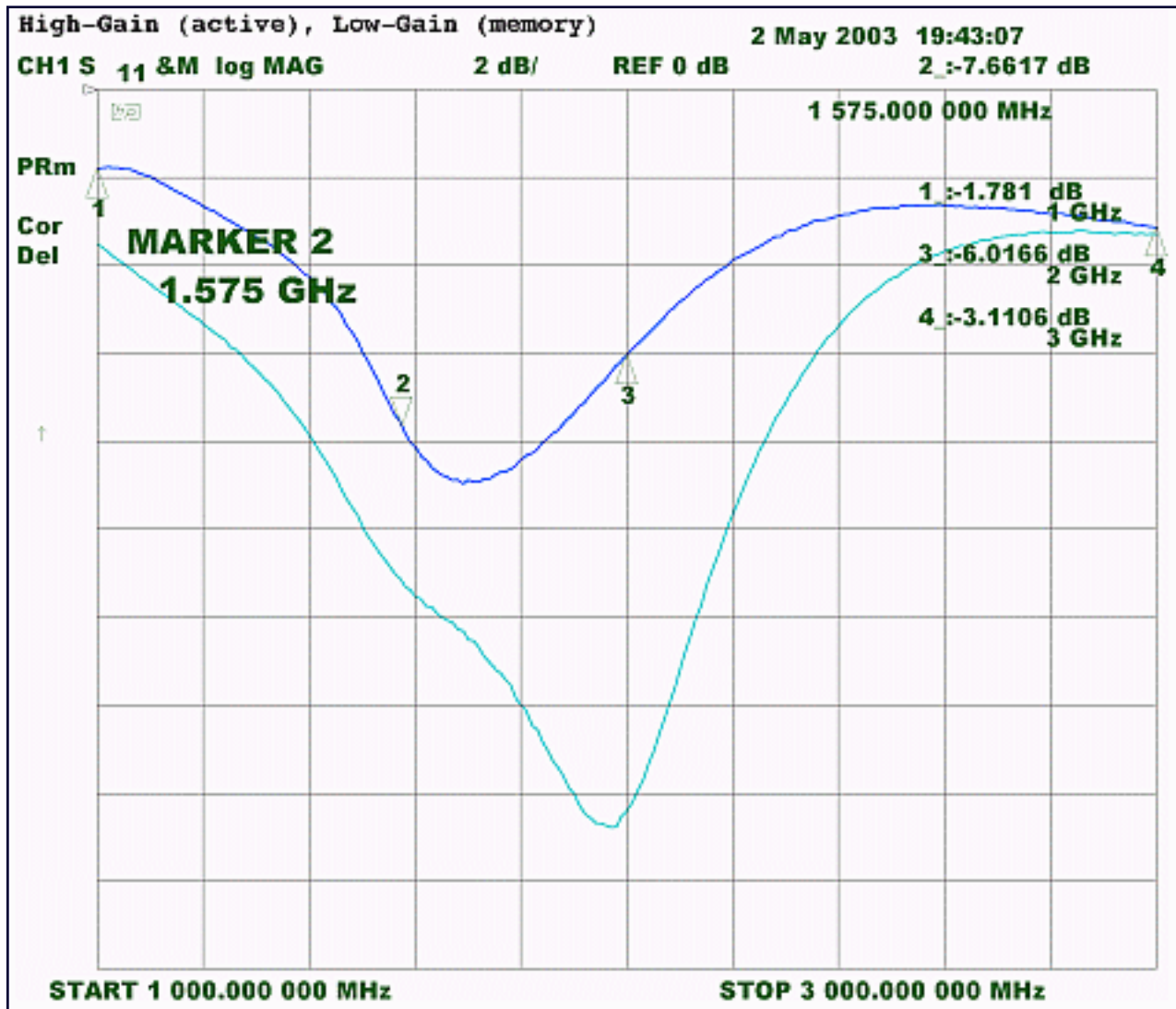

Figure 3. MAX2653 GPS performance, input return loss (S11) for high-gain (active trace) and low-gain (memory trace).

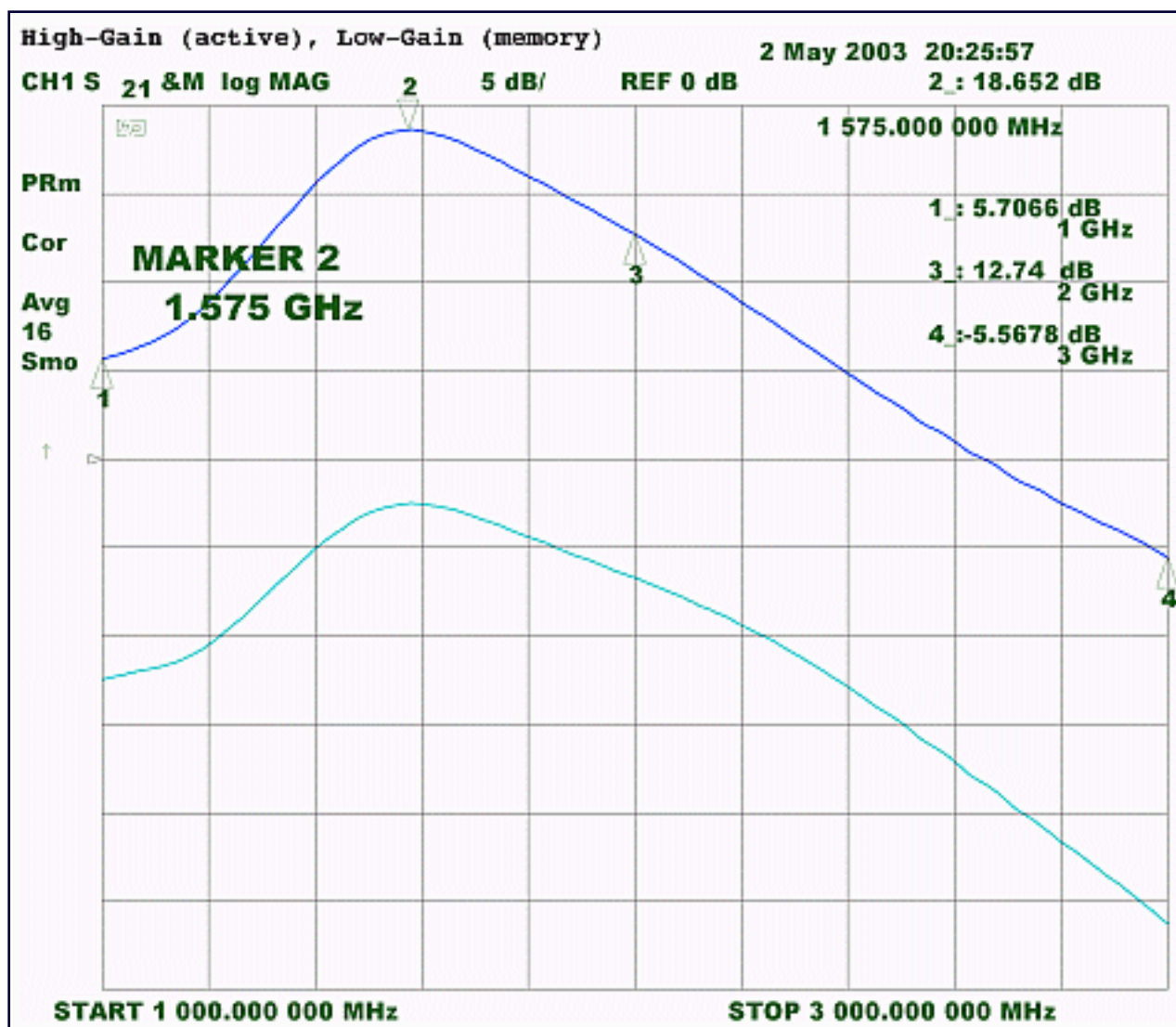

Figure 4. MAX2653 GPS performance, forward gain (S21) for high-gain (active trace) and low-gain (memory trace).

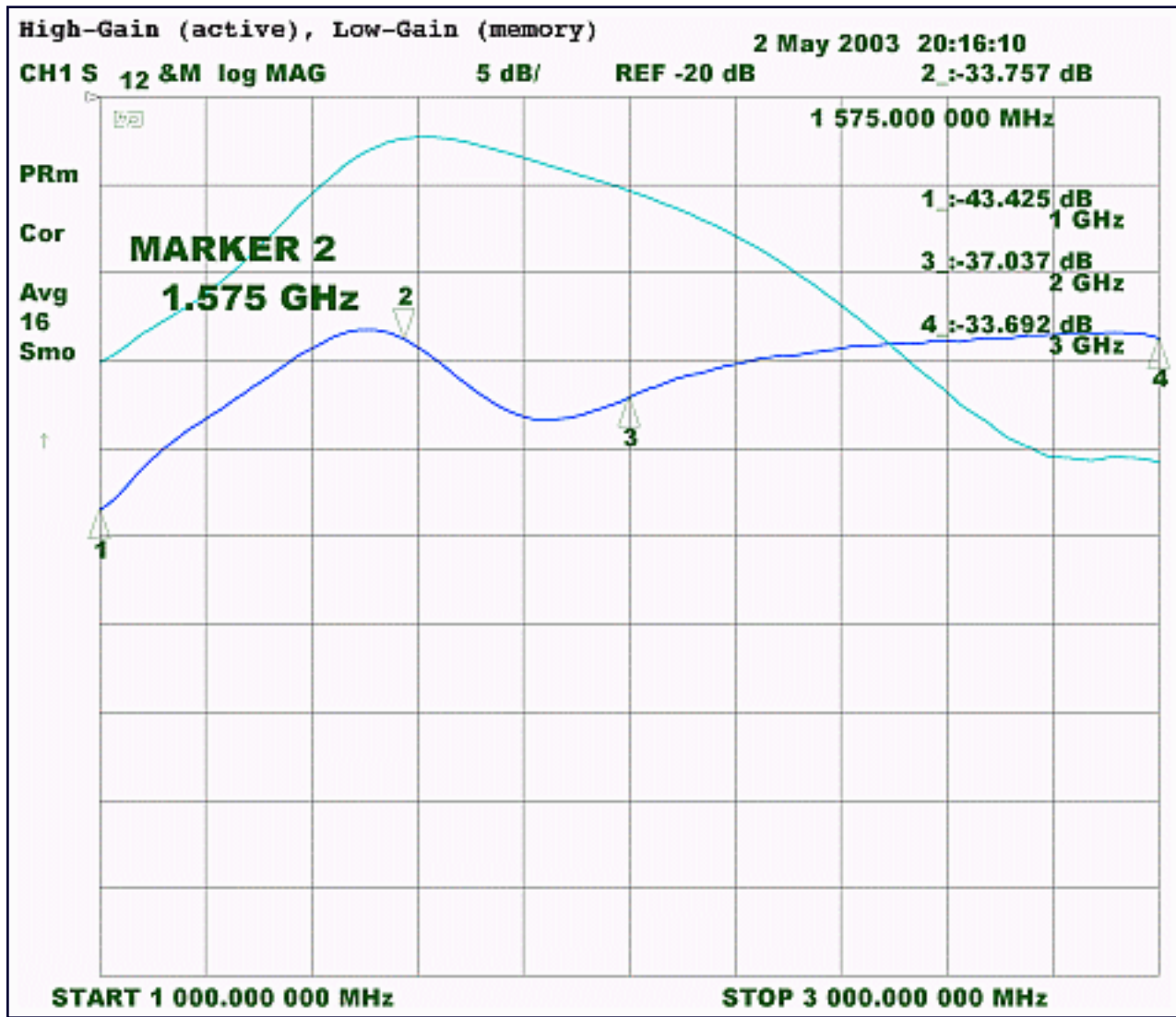

Figure 5. MAX2653 GPS performance, reverse isolation (S12) for high-gain (active trace) and low-gain (memory trace).

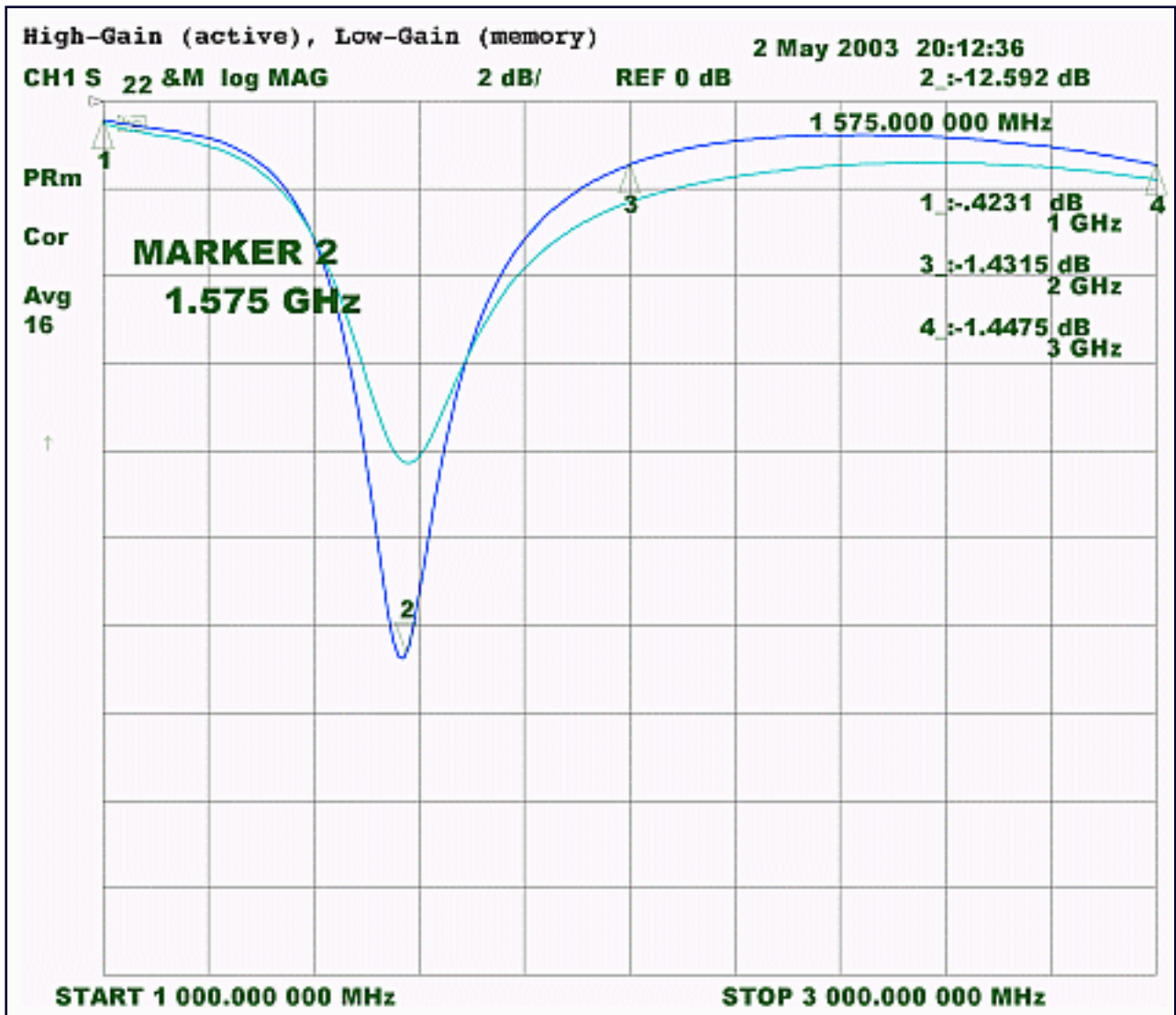

Figure 6. MAX2653 GPS performance, output return loss (S22) for high-gain (active trace) and low-gain (memory trace).

Also See:

[Product Line Page](#)

[Technical Support Page](#)

More Information

MAX2653: [QuickView](#) -- [Full \(PDF\) Data Sheet](#) -- [Free Samples](#)